

MAJOR

WHEEL-FREE

T61720

OPERATION AND MAINTENANCE INSTRUCTIONS

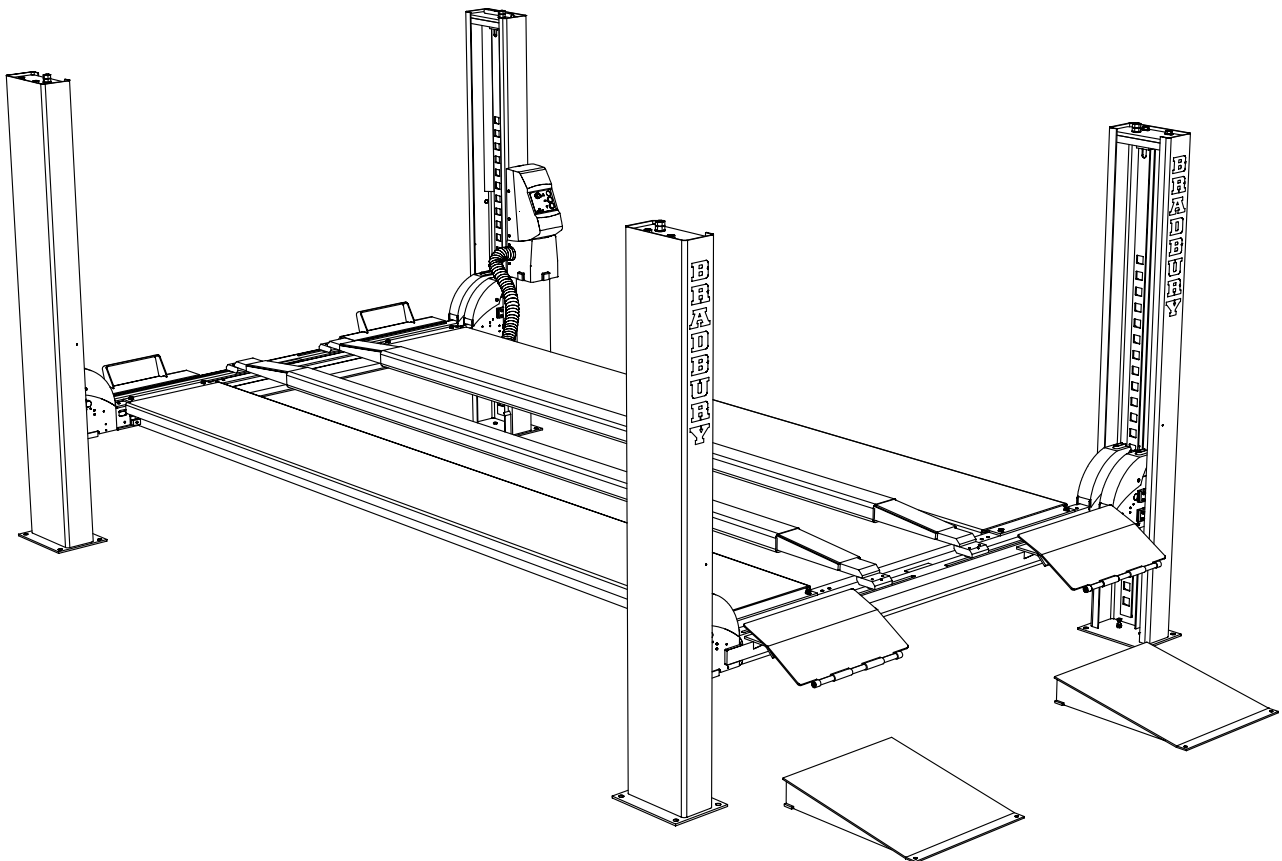

Bradbury Equipment
153-165 Bridge Street
GB- Northampton NN1 1QG
England
Tel. +44 (0) 1604 828 648

Date: 270307	Serial No:
Ref.: KM/LJE	Pages: 10

OPERATION AND MAINTENANCE INSTRUCTIONS

This lifting device is specially developed to lift motor cars and we strongly recommend not to lift any other equipment with this automotive car lift.

DESCRIPTION

The lift is an electro-hydraulic 4 post surface-mounted lift with capacity ranging from 3 to 5.2 t.

The lift consists of 2 pairs of posts connected with cross beams. The 2 platforms rest on the cross beams.

Furthermore, the lift is equipped with a wheel-free device; which consists of 2 cross beams placed on the outer sides of the main cross beams and a pair of rails fitted to the wheel-free cross beams.

Platforms and cross beams for the main lift are raised and lowered by means of cables and a hydraulic cylinder placed under one platform. The cables are attached to a yoke on the piston rod and run via cable pulleys to the four post tops with an incorporated adjustment device.

The hydraulic pump unit and control box are placed on the front right post.

The lift is operated by means of pushbuttons showing the UP, DOWN and PARKING functions with indicators. Furthermore, the control unit is fitted with a rotary switch for activation/deactivation of the wheel-free device.

Sound level measured at the control unit at a height of 1.6 m: max. 74 dB(A).

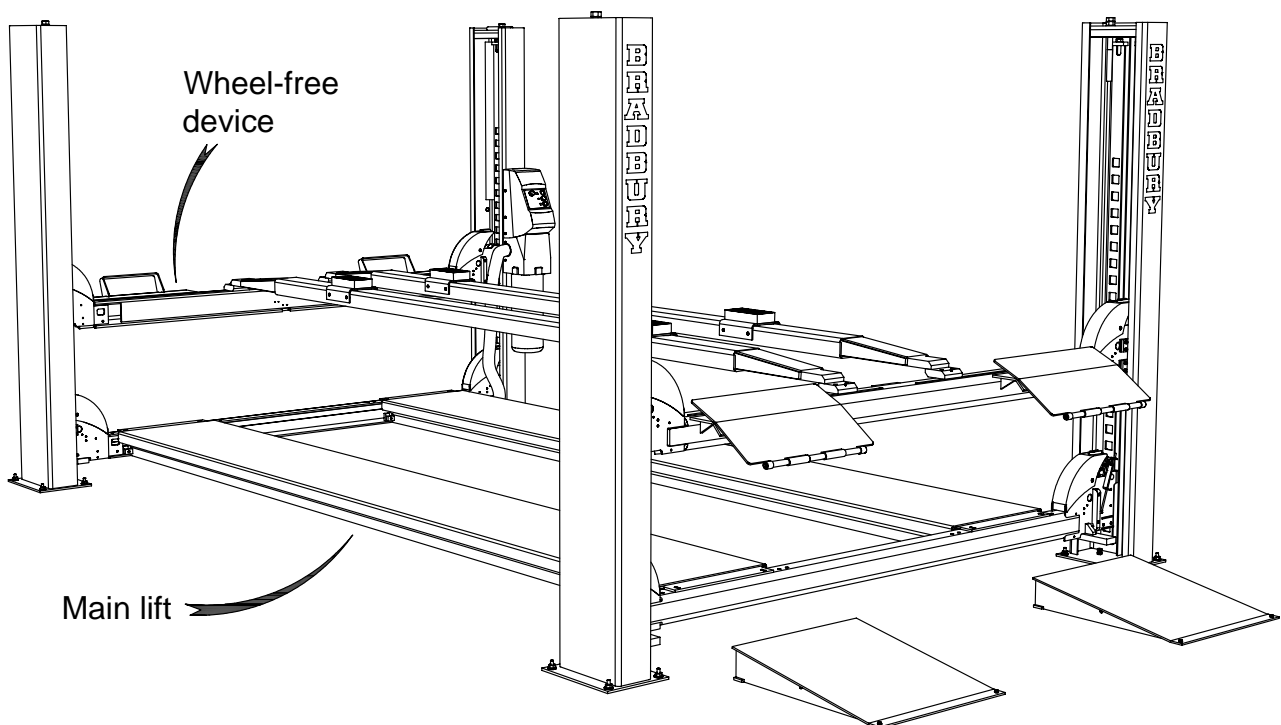

INSTALLATION

In order to come up to your expectations now and in the future the lift must be installed in strict accordance with the installation instructions and maintained according to our recommendations.

Contact your distributor for the name and address of the nearest authorized service shop.

FITTER INSTRUCTIONS

Install the lift in strict accordance with the original installation instructions which are included in each delivery.

The lift must be installed on solid foundation: concrete with minimum load capacity 5500 N/m² and surface spot load under posts 350 kN/m²; extraction load for expansion bolts attaching the posts: minimum 5 kN per bolt.

There should be sufficient light for work on and under the lift. For the lift a lighting set is available as an optional extra comprising four impact-proof, water-tight fluorescent tubes including cable (state model number).

Avoid installing the lift in rooms with danger of explosion.

WARNING: Person transportation is forbidden.

OPERATION

The lift should only be operated by trained personnel !

Approach

Before driving the vehicle on to the lift, check that platforms are parallel (the same indicator position at both ends).



Raising

Push UP-button  (motor starts): raise lift to a bit above required working height.

Parking





Let go of UP-button and push PARK-button  until platforms rest on all 4 ratchets.

Lowering

Check that no person or obstruction is under platforms. Push UP-button shortly (to release the 4 ratchets) and then press DOWN-button . The lift then lowers until the lift reaches automatic anti-toe trap device and the lowering stops. Let go of DOWN-button  and re-activate it after approx. 1 sec., the lowering continues until the lift reaches bottom position or until pushbutton is not pressed any more.

NOTE: Always park lift (press  button) before starting to work under it.

Operation Wheel-free:

When pushing UP-button , both platforms and wheel-free device are raised simultaneously. At the height wanted, the rotary switch is activated and the wheel-free device parked. When pushing DOWN-button  the platforms will be lowered. When the job is finished, the platforms are raised till they reach the wheel-free device and the vehicle is set off on the platforms. Deactivate the rotary switch; check that no persons or obstructions are under the platforms and push UP-button  shortly (to release the 4 ratchets). Push DOWN-button  and the lift lowers until it reaches the automatic anti-toe trap device and then stops. Let go of DOWN button; after app. 1 sec. reactivate it and the lowering will continue until the lift reaches bottom position.

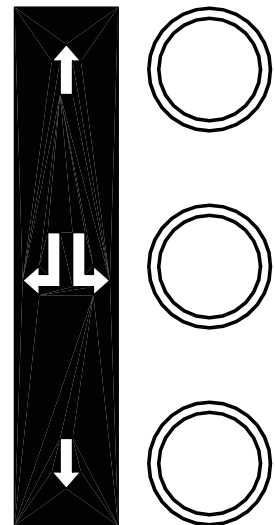

WARRANTY:

This lift is guaranteed for one year, covering faults due to manufacturing or material defects, provided that the enclosed guarantee certificate, filled in and signed, is returned immediately upon installation of the lift and provided that the installation, operation and maintenance instructions are observed.

IMPORTANT ! Product liability accepted only if solely original spare parts have been used.

MAINTENANCE

Oil level check Check regularly the oil level in the reservoir under the pump. Fill up as necessary, correct oil level is in the middle of the oil glass alternatively of dip stick.

Oil change First oil change after one year of operation, thereafter every 6 years.

Oil contents Approx. 8 l (for pump unit with built-on electric motor)
= 6.5 l (for pump unit with plunged electric motor)

Oil type See page 6

Lubrication and maintenance See decals on control post.

CLEANING

Cleaning of 4-post surface mounted lifts to prevent corrosion damages.

Corrosive fluids as brake fluid, oil, fuel or other solvents must be wiped off immediately, otherwise damage will occur to the coating.

Special attention must be paid to the corrosive effect of salt in fall and winter periods.

The cleansing agents must not have any abrasive effect, nor contain solvents.

The lift must be cleaned at least once a week.

The lift must be cleaned with a non-corrosive cleansing agent.

Clean and wipe the lift according to the following scheme:

When:	Where:	How:	Remarks:
Every week	Platforms	Clean and wipe	Wearing surfaces must be slightly oiled
	Drive-on ramps		
	Post / base plate		
	Alu rails for jack		
	Cross beams		
	Rails		

Bradbury Equipment does not accept any claim concerning the paint peeling off or corrosion damages caused by missing or insufficient cleaning or maintenance.

Repair of damages:

Repair of damages on the coating must be carried out immediately in order to minimize the extent of the repair.

The damages will typically be:

1. Damages which do not affect the metal surface but affects the coating itself
2. Damages going down into the metal surface.

Repairs:

Contact Bradbury Equipment for guidance.

Order number for repair paint is to be seen in the spare parts list and contains basic cleanser, primer and paint together with instructions for repair of paint damages.

Please state RAL number of paint.

ADJUSTMENT OF CABLES

Steel cables will stretch depending on the operational load and therefore require adjustment as follows:

- a. Load the lift with approximately 2500 kg (5500 lbs).
- b. Switch off air supply. Adjust wires to make the 4 ratchets engage simultaneously when UP-button is activated.
- c. Raise lift to top position. Check distance from underside of ratchet to underside of hole in ratchet rail; this distance must be min. 20 mm.
- d. Lower the lift to bottom position and check that the platforms rest against their stops. If not, adjustment of cables or ratchet rails is necessary.

CONTROL OF CABLES

Check cables for wear at the monthly lubrication intervals and replace as necessary (see below paragraph concerning scrapping).

NOTE: The monthly lubrication with thin penetrating oil reduces cable wear and prolongs cable life appreciably.

GENERAL: At least once a year the cables must be checked-up by an authorized engineer. Contact your distributor for the name and address of the nearest authorized service shop.

If documentation on cables and/or cable construction is required, please state the stamp on the cable lock. On this request, copy of original certificate will be forwarded.

SCRAPPING OF CABLES

The steel cable must be discarded when:

- the cable is worn-down on more than 10% wear of its nominal diameter
- an individual wire is worn more than 1/3 of the wire diameter
- the number of wire ruptures on a twisting length exceeds 10 on any spot of the cable
- the cable has a kink (pulled-out loop)
- the cable is flattened or cornered, even if there is no wire ruptures
- the wires in a strand are burst
- the cable is damaged by corrosion, even if there is no wire ruptures
- the cable has been damaged through chemical influence.

SERVICE

High pressure cylinder replacement - main lift

To be carried out by trained personne. Please contract your dealer.

- a. Raise the lift to the appropriate working height and allow the safety ratchets to engage.
- b. Remove cables from yoke.
- c. Remove lock nut and screw off yoke. If the piston rod is seized in the yoke, protect the rod surface with either rubber or fibre before using a pipe wrench.

- d. Remove pipe connection to the cylinder, push the piston rod in until the thread reaches the stuffing box and remove the clip holding the cylinder to the platform.
- e. Fit the new cylinder in the reverse order as above.
- f. Raise the lift to the top and lower again to the floor to vent the new cylinder.
- g. Test the lift under load and check pipe connections and stuffing box for possible oil leaks.

Replacement of packings in high pressure cylinder

To be carried out by trained personnel. Please contact your dealer.

Spare parts kit

Spare parts kit for the cylinder contains above mentioned seals:

792425 (AC cylinder with external stuffing box)

794426 Piston seals kit

Spare parts

In order to ensure correct spare parts deliveries please state part number, designation, and quantity (to be seen from spare parts list included in delivery) as well as lift serial number and year of production (to be seen from serial number plate).

EMERGENCY LOWERING (In case of power cut-out) (not single phase lifts)

Turn mains on 0-position.

By means of a jack raise one corner of the cross beam 3-4 mm. Pull out the ratchet and block it with a piece of band. Repeat this in the 3 other corners.

Remove cover of pump unit.

Open carefully emergency lowering valve and lower lift carefully to bottom position. Close emergency lowering valve again and re-fit cover.

OIL SPECIFICATIONS

	- Semi-hydraulic lift (oil in lift cylinder)	- Full-hydraulic lift - High-pressure No lift - 4-post lift - Mistral H - Pit jack - All-purpose lift - Presses	- Scissor lift - 2-post hydraulic surface-mounted - Servicemaster	Lubrication oil for high-pressure lift
Additives:	Anti-foam, anti-corrosion, anti-oxidation			
Other characteristics:	Water-separating			
Viscosity: (cSt=mm ² /s)	75-120 cSt (40°C)	215 cSt (0°C) 32 cSt (40°C)	140 cSt (0°C) 22 cSt (40°C)	65 - 110 (40°C)
Viscosity index:	Min. 90	150	90	min. 70
Pour point:	Max. -10°C	Max. -10°C	Max. -10°C	Max. -10°C
ARAL	Aral vitam gf 100			Aral konit 30
AVIA	Abilub hydr.oil rsl 100			Avilub mk 2000
BP	Energol hlp 100	Bratran hv 32/shf 32	Bartran hv 22	Vannellus m 2030
CHEVRON	Hydraulic oil 100	Mechanism lps 32		EP industrial oil 68
GALP	Hidrolep 100			NR 30
ESSO STATOIL	Nuto hp 100	Hydraway hv 32	Hydraway hv 22	Protectway 32
FINA	Hydran tsx 100	Hydran ts 32	Hydran ts 22	Arusan 30
GULF - Q8	Q8 haydn 100	Q8 haydn 32	Q8 haydn 22	Q8 wagner 68
MOBIL	Mobil dte 18	Mobil dte 24	Mobil dte 22	Mobilarma 524
NYNÄS	Td 39 ex			Td 31 ex
OK	Ok hydraulic oil 65	Super hydr. oil 32		Ultima eph 68
SHELL	Tellus oil (S) 100	Tellus oil 32	Tellus oil 22	Remula x 20 w
NOROL	Hydraulikolje hm 100			Lagringsolje sae 20
TEXACO	Rando oil 150	Rando oil hd 32	Rando oil hd 22	Regal oil R&O 100
IGOL	Sonhodro 100/hydro 30			Relax
VALVOLINE	Ultramax hlp 100	Ultramax hvlp 32	Ultramax hvlp 22	Ultramax hlp 68
SUNOCO	Sonvis 8100 wr 100	Sunvis 832 wr-hv	Sunvis 822 we-hv	Sunfill 2630
ELF	Elf olna 100	Olna ds 32	Olna ds 22	Olna ds 100
CASTROL	Hyspin aws/awh 100	Hyspin awh 32	Hyspin aws 22	Rustilo 652

TROUBLE SHOOTING CHART

SYMPTOM	CAUSE	REMEDY
A. Platforms no longer horizontal when hanging in cables under load (approx. 1000 kg, 2200 lbs)	One or several wires stretched	Adjust wires (see page 4)
B. Platforms no longer horizontal when resting on the ratchets	Incorrect adjustment	Adjust platforms and cross beams until they are horizontal. Slacken nut under top plate for rail. Raise or lower ratchet rails as required by means of adjustment bolts in top of posts. After adjustment tighten lock nut under top plate for rail. Ratchet rails should preferably be adjusted to lowest possible position.
C. Activation of control to lower lift from topmost position does not release ratchets	One or more of the cables have stretched	Adjust cables (see page 4).
D. Ratchets are not released regardless of parking height	Air source failure	Cure fault
	Incorrect air pressure	Cure fault (min. 7 bar - max. 10 bar)
	Platforms are not lifted free from ratchet rails	Raise lift a little and lower.
	One ratchet binding	Let an assistant operate UP-button so that lift ascends in small jerks. Meanwhile pull ratchet free manually. Use pliers or grips.
E. Ratchets fail to activate	Air system blocked	Strip and clean air system
F. Oil leakage	High pressure hose defective	Replace hose
	Leaks at fittings	Tighten
	Cylinder seals defective	Replace or renovate cylinder
G. Unusually high noise level	Pump worn	Replace pump
	Lift overloaded	Max. load - see decals
	Seal in high pressure cylinder defective	Replace or renovate cylinder
	Incorrect post position	Re-position posts according to installation instructions
	Oil pressure release valve out of adjustment	Adjust: 4 t = 230 bar 5.2 t = 320 bar

TROUBLE SHOOTING CHART (continued)

SYMPTOM	CAUSE	REMEDY
H. Lift cannot ascend	Overloading	Max. load - see decals
	Insufficient pressure from pump unit	See step M
I. Lift cannot descend	Pump does not start	See step L
	One or more of the ratchets still activated	Lift free from ratchet rails before lowering
	Air system blocked	See step E
J. Lift cannot reach topmost position	Insufficient oil in pump unit	Fill up oil until middle of oil glass/dip stick with platforms at floor level. Oil type: see oil specifications on page 6.
	Incorrect wire adjustment (too long)	See page 4
K. Platform descends when ratchets are not engaged	Leaks in hydraulic system	See step F
	Lowering valve/ non-return valve leaking (internal in the pump unit)	Call authorized service engineer
L. Pump unit cannot start	Electric failure	Check fuses.
	Incorrect electric connections	Call authorized electrician
	Fault in control box	
	Faulty electric motor	
	Defective pushbutton	Replace
M. Pump unit delivers none or insufficient pressure	Pump defective	Replace pump
	Air in hydraulic system	Lower platforms to bottom position without load and keep pressing DOWN-button for approx. 20 sec.
	Non-return valve or oil pressure relief valve defective (internal in pump unit)	Call authorized service engineer

CONTROL LIST FOR MAJOR

<u>CHECK</u> that the technical manuals are delivered with the lift (installation instructions, operation and maintenance instructions, spare parts list, the general guarantee certificate, the EC-certificate of conformity, the electrical diagram in the control box) <input type="checkbox"/>	
<u>CHECK</u> that all components are enclosed (see installation instructions T70729 and the accessory kit packing list) <input type="checkbox"/>	
<u>CHECK</u> the lift for any paint damages occurred during transportation, or paint faults from the production <input type="checkbox"/>	
Follow the installation instructions T70729 delivered with the lift and check the following points: <input type="checkbox"/>	
PLATFORMS AT FLOOR LEVEL	Cross beams rest against their stops at floor level (all cables loose) <input type="checkbox"/> Posts are vertical in both directions <input type="checkbox"/> Right-hand platforms can be slid freely along cross beams <input type="checkbox"/> The two nuts for cables at top of posts are counter-tightened <input type="checkbox"/> Eccentric brake sensory rollers are free to rotate on axles <input type="checkbox"/> Oil level in accordance with "oil level control" (oil level: middle of sight glass) <input type="checkbox"/> Important signs/decals: * Max. capacity <input type="checkbox"/> * Maintenance + safety instructions (placed on control post) <input type="checkbox"/> * Several warning labels <input type="checkbox"/> * Name plate with CE-label <input type="checkbox"/>
PLATFORMS HANGING IN RATCHETS AT APPROX. 1 M'S HEIGHT	High pressure hose fittings are tight <input type="checkbox"/> Armoured hose hangs freely as a "U" without strain <input type="checkbox"/> Air system checked for leaks <input type="checkbox"/> Platforms and cross beams are horizontal when lift is parked in ratchets <input type="checkbox"/> Cables are correctly fitted (see installation drawing) <input type="checkbox"/>
NON LOADED LIFT	Excess-pressure valve is activated when platforms reach the topmost position (audible) <input type="checkbox"/>
LOADED LIFT (APPROX. 1.5 T)	Platforms can be parked in the topmost ratchet holes (cable adjustment) <input type="checkbox"/> Platforms can be released and lowered from topmost ratchet holes (tolerance approx. 15 mm) <input type="checkbox"/> Nylon slide blocks on cross beams must not touch (tolerance 0-0.5 mm) (post adjustment – cross beam adjustment). Check that ratchet rail does not fret the cross beam <input type="checkbox"/> Platforms horizontal when hanging in cables with load and no air connected. If lift adjustment is correct only <u>ONE</u> click should be audible from all ratchets during upwards movement. If not - adjust. <input type="checkbox"/>
INSTRUCTION	The enduser has been thoroughly instructed in correct use and maintenance <input type="checkbox"/>
CONCLUSION	Write any defects/faults on the enclosed note-scheme and return/fax a copy of <u>this</u> control list (both pages 9 and 10) to: Bradbury Equipment 153-165 Bridge Street GB- Northampton NN1 1QG England Tel. +44 (0) 1604 828 648
RECEIPT	The above check-up has been made and the lift has been tested with a vehicle (total weight _____ kg) Serial No. of lift: _____ Installation date: Responsible workshop manager: _____ Fitter: _____

