

made
in
Germany

Low profile,
space-saving
double scissor lift
with a 3000 kg
lifting capacity

Nussbaum JUMBO LIFT NT



The ideal space saving lift; it is versatile enough to handle most repairs and servicing with clear access to the vehicle while being extremely compact. The Jumbo Lift NT has the potential to maximise workshop productivity through the optimal utilisation of space.

FEATURES

- Lifting capacity 3000 kg
- Very low drive-on height (98 mm)
- High lifting height (2000 mm)
- Space saving and unobstructed floor (no posts, no frame); 5 Jumbo lifts can fit into the same area as 4 traditional lifts
- Very fast and quiet operation
- Nussbaum NT full Hydraulic power system; no compressed air required
- Lift can be easily relocated if require
- Aluminium plated drive-on ramps and pick-up platforms
- Adjustable length pick-up platforms
- Teflon coated bearings
- Above-ground or In-ground installation possible
- Build for longevity with the cylinders hard & hot chromed as well as lubrication points on every pivot point of the lift
- Originally developed and produced by Nussbaum
- Made in Germany



Molnar Hoists are the Australian agents for Nussbaum, for more information, please contact us on:

T 08 7120 8700 or 1300 MOLNAR (within Australia) **F** 08 8346 0097
E sales@molnarhoists.com.au www.molnarhoists.com.au

onwards & upwards

Nussbaum

JUMBO LIFT NT 3 TONNE DOUBLE SCISSOR LIFT

made
in
Germany

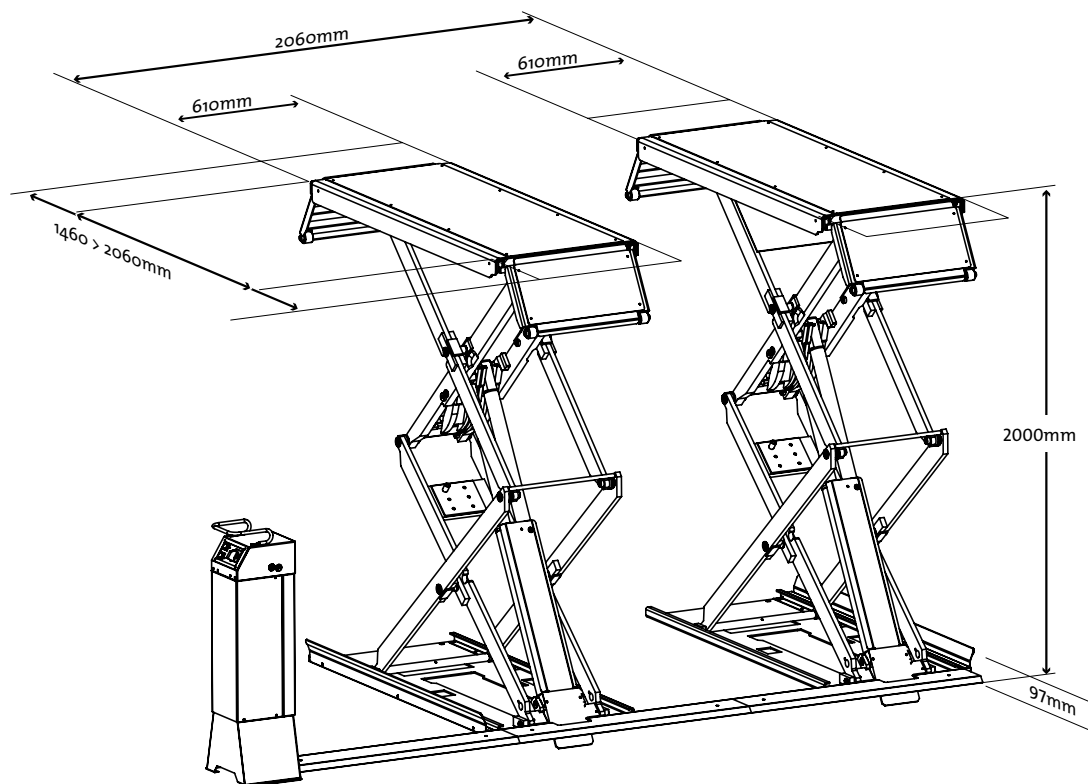

PRODUCT SPECIFICATIONS

Footprint	2020 x 2060 mm
Length	2060 mm
Width	2020 mm
Height	98 – 2000 mm
Lifting Capacity	3000 kg
Maximum Raised Height	2000 mm
Minimum Lowered Height	98 mm
Minimum Lifting Time	30 seconds
Platform Width	610 mm
Platform Length	1460 - 2060 mm (Adjustable)
Motor	3 Phase, 3 kW, 400 V, 50 Hz
Required Air to Control Unit	N/A
Required Fuse	16 A
Finish	Powder Coated for added durability Aluminium plated ramps and platforms
Concrete Depth	Thickness 160mm, Quality C20/25 (B25)
Hydraulic Oil	high quality, 32 weight, anti-wear
Gross Weight	920 kg
Warranty	12 Months

FEATURES

Operational	Control Unit separate from Lift
	Push buttons for raise & lower
	Adjustable runway length
	Polymer pads included for sill panel pick up
Safety	Pressure relief valve (prevents overload)
	Foot protector
	Lockable main switch (protects against unauthorised operation)
	Deadman controls (automatic stop when released)
	Safety device against unintentional lowering
	Nussbaum NT dual independent cylinder system (master and slave redundancy)
	Meets Australian Standards AS/NZ 1418.9:1996
Design Registration Number SD-20122190-1	

Documentation Comprehensive service and installation instructions included

ACCESSORIES

Aluminium crossbar with transversally adjustable pick up pads.
Polymer pad: two sizes [50 x 150 x 340mm] or [100 x 150 x 340mm]
Extensions for hydraulic hoses (between the scissors and control unit) in different lengths as well as the corresponding galvanized cable cover.

OPTIONS

"Oxygen" coating for corrosive environment (dark grey)
Special colour with RAL-Colour Powder coating

Manufacturer reserves the right to change specifications without notice.



Molnar Hoists are the Australian agents for Nussbaum,
for more information, please contact us on:

T 08 7120 8700 or 1300 MOLNAR (within Australia) F 08 8346 0097
E sales@molnarhoists.com.au www.molnarhoists.com.au

onwards & upwards