

Platform scissor lift  
with a maximum  
4000 kg lifting  
capacity

made  
in  
Germany

# Nussbaum UNI LIFT 3500 NT



An icon of Nussbaum innovation and quality, the Uni Lift is a solid and space saving solution for general repair, test lanes, car reception areas and wheel alignment. The Uni Lift can also be installed in-ground or above-ground.

## FEATURES

- Maximum lifting capacity 4000 kg
- Small footprint, space saving and unobstructed floor (no posts, no frame)
- Fast lifting time (35 seconds)
- Low drive-on height (195mm)
- Nussbaum NT full Hydraulic synchronisation (no electrical sensors, electrical connections or mechanical connections required)
- Powerful and Quiet; oil-submerged power unit
- Originally developed and produced by Nussbaum
- Made in Germany



*Molnar Hoists are the Australian agents for Nussbaum, for more information, please contact us on:*

**T** 08 7120 8700 or 1300 MOLNAR (within Australia) **F** 08 8346 0097  
**E** sales@molnarhoists.com.au **www.molnarhoists.com.au**

*onwards & upwards*

# Nussbaum

## UNI LIFT 3500 NT 4 TONNE PLATFORM SCISSOR LIFT

made  
in  
Germany

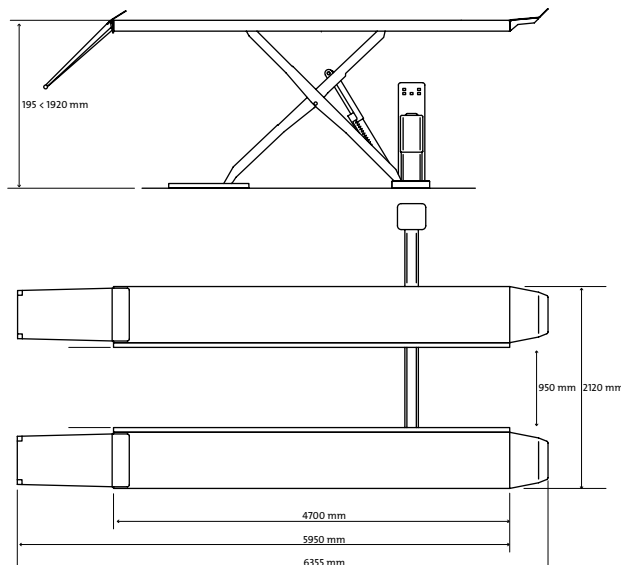

### PRODUCT SPECIFICATIONS

Footprint	2120 x 6355 mm
Length	6355 mm
Width	2120 mm
Height	195 ▶ 1920 mm
Lifting Capacity	4000 kg (3500 kg wheels free)
Maximum Raised Height	1920 mm
Minimum Lowered Height	195 mm
Minimum Lifting Time	35 seconds
Platform Width	635 mm
Platform Length	4700 mm (4250mm max vehicle wheelbase length)
Wheel Free Lift (WFL) Length	1485 ▶ 1945 mm
WFL Height Above Runway	50 ▶ 580 mm
Motor	3 Phase, 3 kW, 400 V, 50 Hz
Required Air to Control Unit	N/A (6–10 bar required for Alignment model)
Required Fuse	16 A
Finish	Powder Coated for added durability
Concrete Depth	Thickness 160mm, Quality C20/25 (B25)
Hydraulic Oil	high quality, 32 weight, anti-wear
Gross Weight	2200 kg
Warranty	12 Months
Documentation	Comprehensive service manuals and installation instructions included

### FEATURES

Operational Control Unit separate from Lift, designed for front left positioning
Push buttons for raise & lower
WFL option; easy to change between main lift and WFL operation
Safety Pressure relief valve (prevents overload)
Foot protector
Lockable main switch
Deadman controls (automatic stop when released)
Safety device against unintentional lowering
Nussbaum NT dual independent cylinder system (master and slave redundancy)
Meets Australian Standards AS/NZ 1418.9:1996
Design Registration Number SD-20122273-1

### ACCESSORIES

Axle Jack 2000 or 2500 (2000 or 2500 kg lifting air hydraulic jacking beam)
Laser Jack 2500 (2000 kg lifting capacity pneumatic jacking beam)
Ramps Longer (for low clearance vehicles, 1500 mm) or Drive-through
Crossbar for wheel-free lifting of heavier vehicles without sill panel
Extensions for Hydraulic hoses (between the scissors and control unit)

### OPTIONS

4500 mm length runway
Coating Options [Powder Coated, 3M Foil, Fire Galvanised, Oxygen Coating]
Joint play detector with integrated light and remote control
Runway integrated lighting
Integrated Axle Jack air supply
<b>A</b> Alignment version with rear sliding plates and front recesses for turntables and compressed air locking system.
<b>PLUS</b> Wheel-free lift version (a small sill panel lifting scissor lift, integrated in each runway combined max lift capacity 3500 kg)
<b>CLT</b> Lifting and locking with Nussbaum proprietary SST cylinders
<b>IN-GROUND</b> Vertical adjustable roll off protectors for in-ground installation.

Manufacturer reserves the right to change specifications without notice.



Molnar Hoists are the Australian agents for Nussbaum,  
for more information, please contact us on:

T 08 7120 8700 or 1300 MOLNAR (within Australia) F 08 8346 0097  
E sales@molnarhoists.com.au www.molnarhoists.com.au

**onwards & upwards**