

FOUR TONNE

4 TONNE TWO POST HOIST

2P4T-PREMIUM

MOLNAR



HOISTS

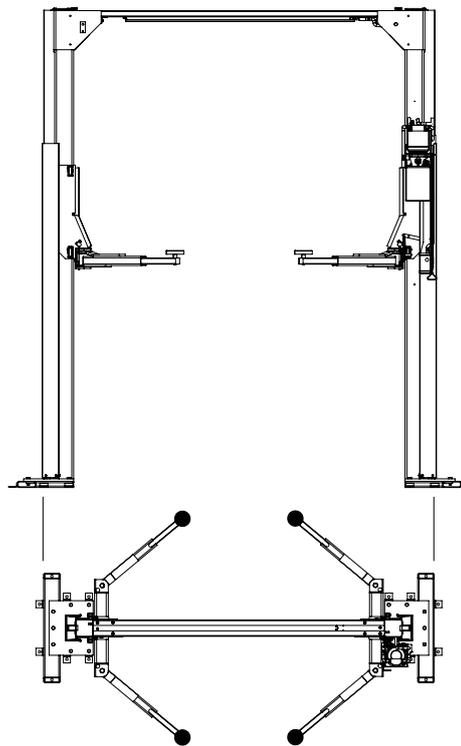
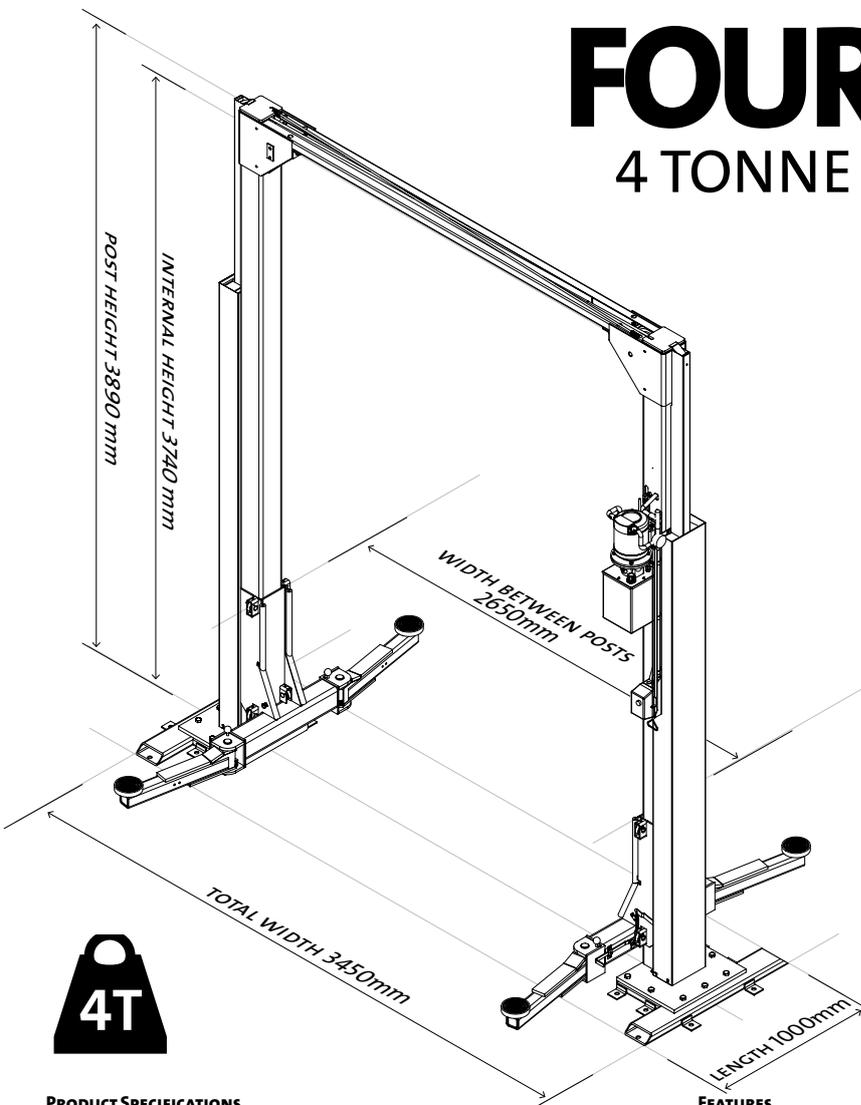

PRODUCT SPECIFICATIONS

Footprint	3450 x 1000 mm
Length	1000 mm
Width	3450 mm
Height	3890 mm ♦
Preferred Clearance Height	150 mm above Height, for installation
Width Between Posts	2650 mm
Width Between Carriages	2420 mm
Height to Beam	3740 mm
Maximum Raised Height	1900 mm
Minimum Lowered Height	115 mm
Length of Lifting Arms	625 mm min, 950 mm max
Motor	3 Phase, 3 HorsePower, 415 Volt * (requires 3 Phase and Earth, 5 Amp)
Lifting Capacity	4 tonnes
Minimum Lifting Time	35 seconds
Concrete Depth	min 100 mm, mesh reinforced, min strength 25 MPa
Hydraulic Oil	high quality, 46 weight, anti-wear
Gross Weight	960 kg
Shipping Dimensions	1.0 x 0.65 x 4.1 metres
Finish	powder coated for added durability
Warranty	3 years

As the policy of Molnar Hoists is one of continuous improvement, the manufacturer reserves the right to change specifications without notice.

FEATURES

Operational	auto release arm lock — automatically unlocks when hoist is lowered to ground
	push button to lift; handle to lower
	soft foam door buffers on carriage
	clear floor access
	140 mm diameter rubber pick-ups
Safety	deadman controls (automatic stop when released)
	safety sensor bar (automatic stop when touched)
	protection for cable breakage, overload and hydraulic failure
	meets Australian Standard AS/NZ1418.9:1996
Service & Installation	comprehensive service manuals and installation instructions included

CUSTOMISATION

Height	♦ different post heights available:	Micro	3300 mm
		Small	3500 mm
		Medium	3600 mm
		High	4200 mm
Colour	extensive range of powder coated colours available		
2P4T-PREMIUM-240VOLT	* optional single phase, 240 Volt motor (requires 240 Volts under load at motor, hard wired on 20 Amp circuit)		

OPTIONAL ACCESSORIES

JJ3	Pick-Up Pad, Large (helps stabilise vehicle)
J3AB	Stabiliser Pad (helps stabilise vehicle)
EP10	Extension Pads (provides additional clearance)



For more information, please contact us or your local Molnar Representative

T 08 7120 8700 F 08 8346 0097
 E sales@molnarhoists.com.au
 www.molnarhoists.com.au

onwards & upwards