

Lifting Britain since 1896

H2401B 4.0 Tonne Two Post Lift

Product Description

This Bradbury H2401B two post lifts are electro-hydraulically operated and are suitable for lifting most cars and small vans. With a low pad height of just 95mm and screw adjustable lifting pads, this lift is very versatile.

This lift is available in single phase only.

Key Features

- 4.0 tonne
- Hydraulic lifting application
- Full base frame for support
- Single phase
- Symmetrical multi-purpose lift
- 1 Year Warranty

Technical Specifications

Lifting capacity	4000 kg
Lifting & lowering time	50 seconds
Minimum height	95mm – 135mm
Maximum height	1900mm – 1935mm
Front minimum arm length	635mm
Front maximum arm length	1,072mm
Rear minimum arm length	850mm
Rear maximum arm length	1,462mm
Motor size	1 Phase 1.8kw
Power Requirements	1 – 16a Isolator Required
Operation	Electro-hydraulic

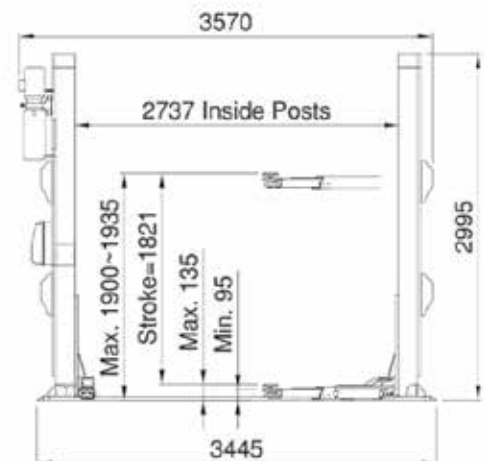
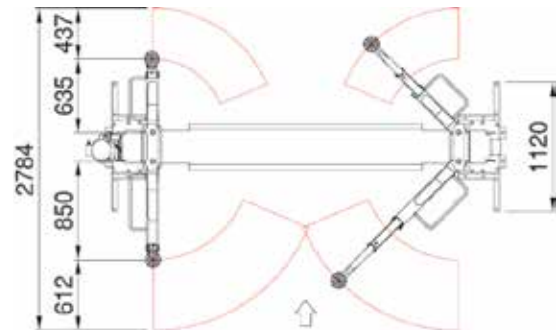

Specifications/Images subject to change without prior notice. E&OE Images are for illustration purposes only. To validate warranty, proof of a valid maintenance contract will be required.