

3x230Vac+PE
1kA<Ik max.<6kA

3x400Vac+N+PE
1kA<Ik max.<6kA

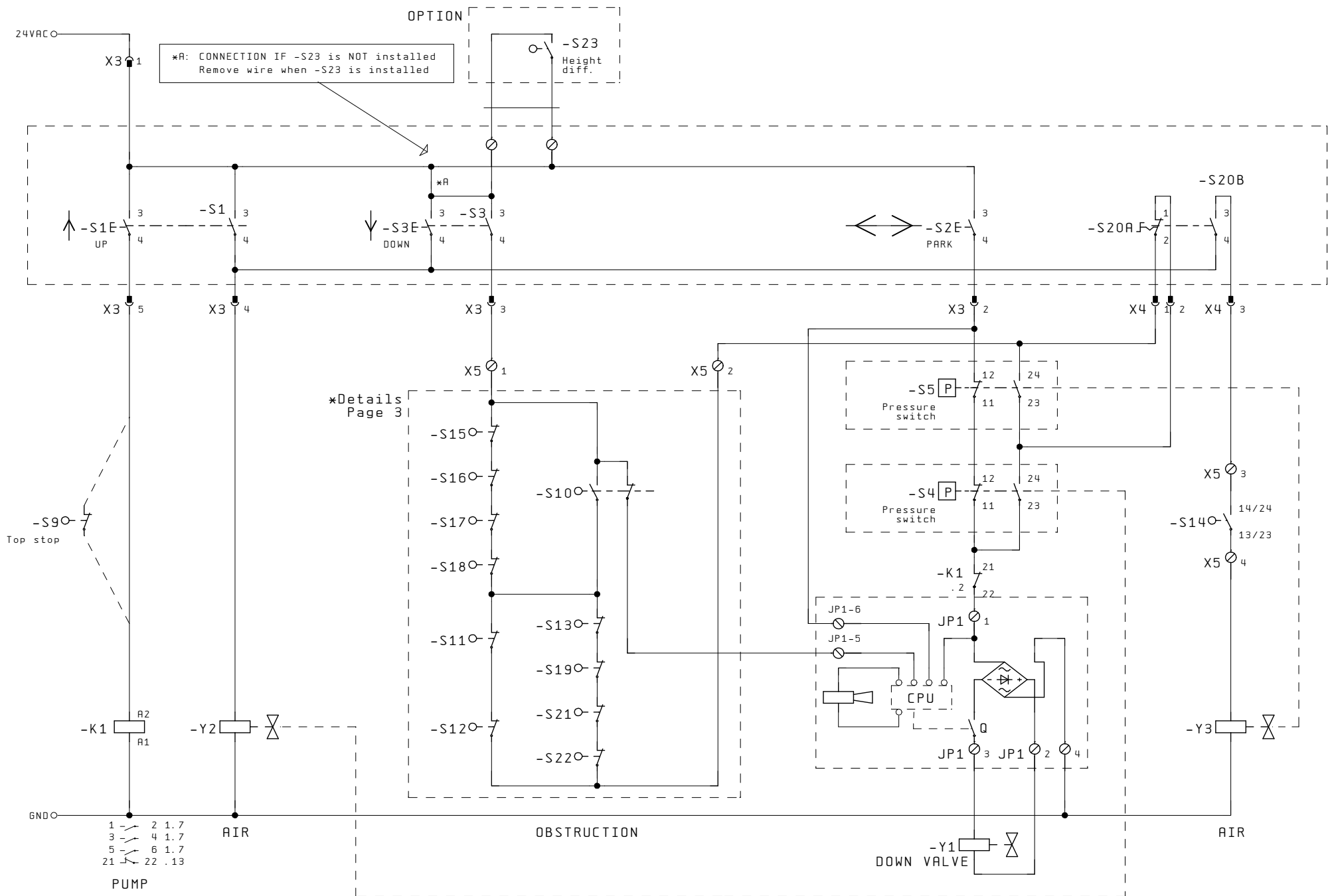

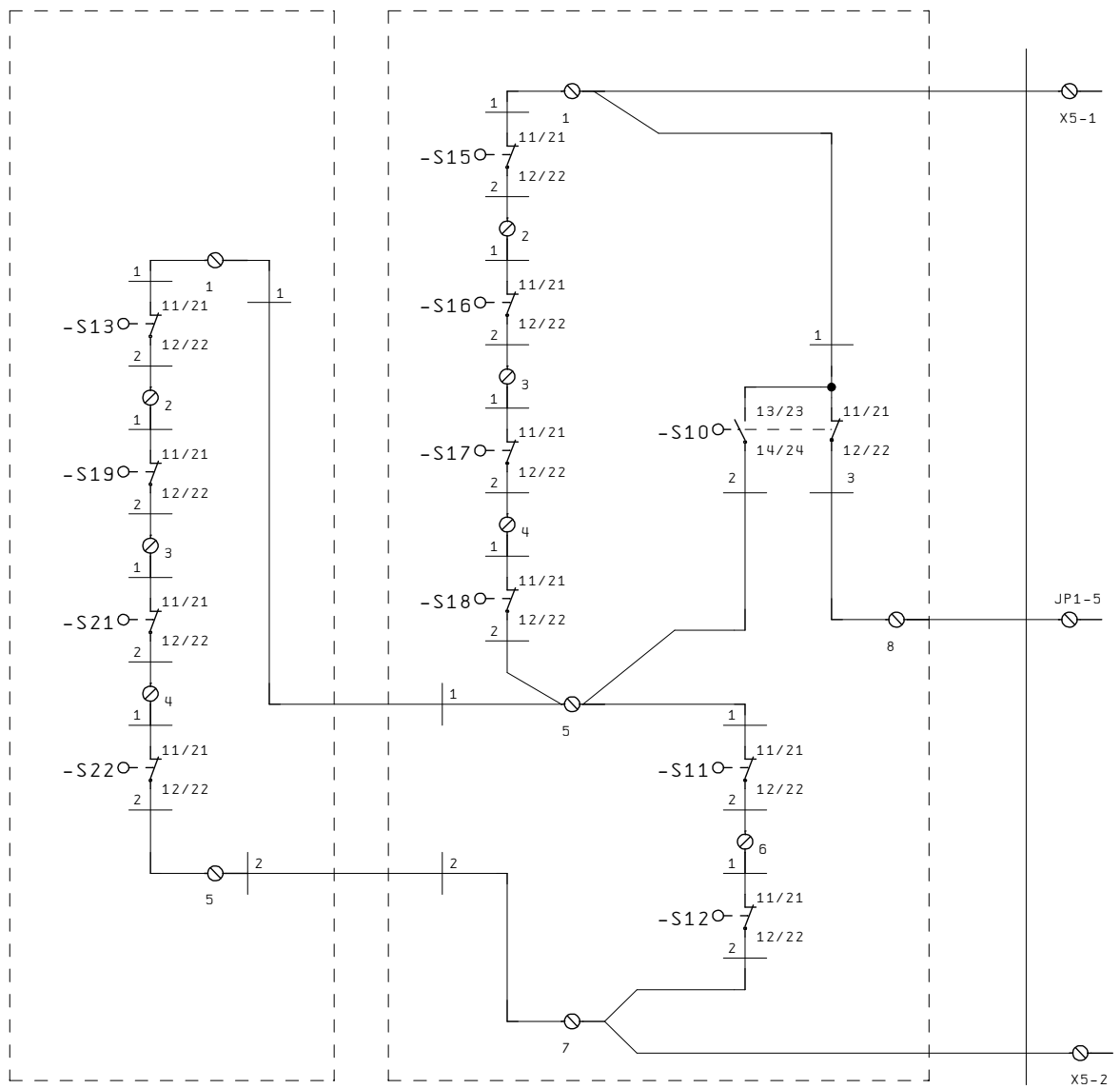

OBSTRUCTION

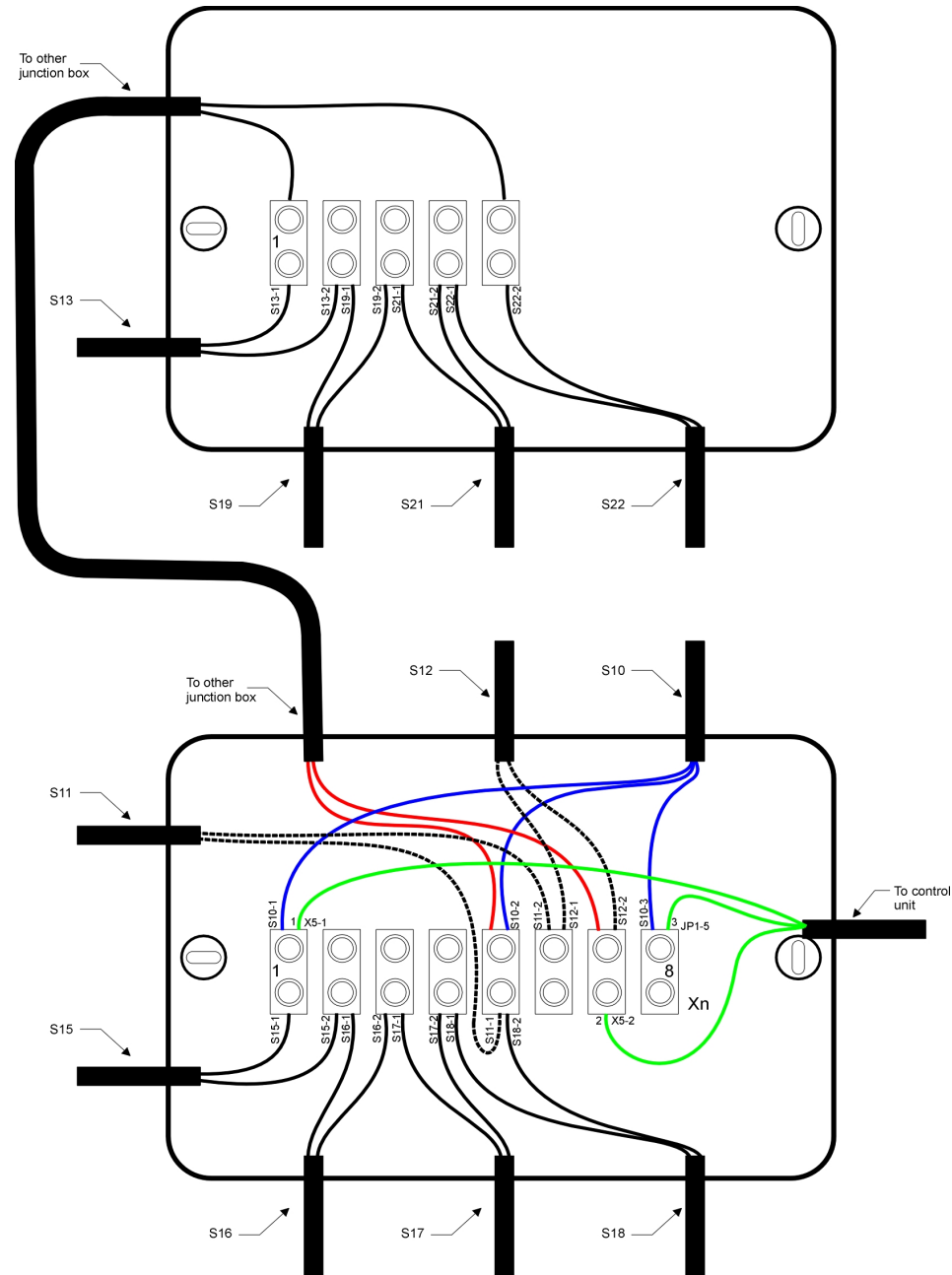

Limit switches:

- S10: Limit switch for jumping the obstruction system on main lift, when lift is in bottom position.
- S11: Limit switch for obstruction system for wheel free device - rear
- S12: Limit switch for obstruction system for wheel free device - front
- S13: Safety switch for ratchet when parking front right wheel-free cross beam.
- S14: Limit switch for jumping S20 (in order to avoid that ratchets on safety ratchets are pulled, when wheel free device is parked).
"Normally open" contacts has to be used in this switch.
- S15: Limit switch for obstruction system on main lift
- S16: Limit switch for obstruction system on main lift
- S17: Limit switch for obstruction system on main lift
- S18: Limit switch for obstruction system on main lift
- S19: Safety switch for ratchet when parking front left wheel-free cross beam.
- S20: Rotary switch for control of the Y3 valve
- S21: Safety switch for ratchet when parking rear right wheel-free cross beam.
- S22: Safety switch for ratchet when parking rear left wheel-free cross beam.
- S23: Limit switch for Max height difference between wheel-free and platform.

REV.	5
Project date	14. Mar. 2007
Printed	09. Sep. 2019