



SM245

Universal Electro-Hydraulic Two Post Vehicle Hoist – 4.5 Tonne Capacity



The MOLNAR SM245 is a universal 4.5 tonne electro-hydraulic two post vehicle hoist, available with three phase or optional single-phase motor. This hoist is ideally suited for vehicle repair and maintenance within industrial, commercial or domestic workshops.

The patented double W shaped post profile and large foot plate offer unrivalled stability for stronger, smoother operation. The double telescopic arm length makes the SM245 one of the most versatile on the market, suitable for the smallest car to the large SUV's.



Features

Posts

- › Vehicle rear positioning for optimum door opening angle
- › Unique asymmetric column design for greater stability
- › Clear floor (no base frame)
- › Single hydraulic unit
- › Carriage with slide blocks
- › Push button control unit with upper protection limit
- › Mechanical synchronisation
- › Safety ratchet system (no expensive compressed air required)
- › Dual height settings

ARMS

- › Double telescopic front and rear arms as standard
- › Ability to parallel park arms; eases pad positioning
- › Automatic arm locking system
- › Very low minimum height
- › Suitable for small to large passenger cars

Settings

- › Standard width 3245 mm or wide 3495 mm
- › Standard height 4000 mm or low 3750 mm
- › Wide model available (250 mm wider) – cable kit required when installing in wide and standard height setting
- › 100 mm Pad Extension included

Optional Extras

- › Single Phase
- › Custom colours
- › Wide and standard height setting fitting kit

Accessories

- › Range of lifting pads
- › Installation kit – oil and bolts
- › 40 mm, 100 mm, 187 mm pad extensions
- › Longer rear arm set for wide hoist setting (880–1560 mm)

Service and Support

- › 3 year Warranty
- › Available spare parts; shipped within 24 working hours

Application



Repair and maintenance



Technical Data

Lifting capacity	4500 kg
Lifting height	95 mm – 1890 mm
Working height	1890 mm
Lifting / lowering time	30 seconds
Motor unit	3 kW
Voltage	415V 3 Phase + Earth (Neutral NOT required) Optional single phase

Arm Structure

Lifting pad	95 – 140 mm adjustable
Minimum height	95 mm
Drive-through width	2250 mm + optional 250 mm
Width between posts	2560 mm + optional 250 mm
Total width - outer edges base plates	3245 mm + optional 250 mm
Total height including post	4000 mm or optional 3750mm low setting
Arm length front, minimum – maximum	590 – 995 mm
Arm length rear, minimum – maximum	710 – 1275 mm

UNIQUE FEATURES



**EASY OPERATION.
AUTOMATIC LOCK RELEASE**

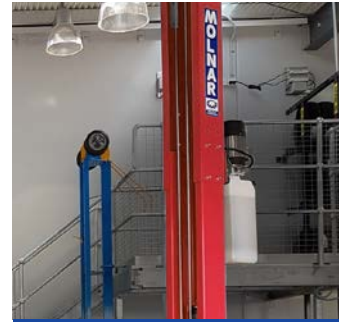

POWER PACK ABOVE OPERATOR

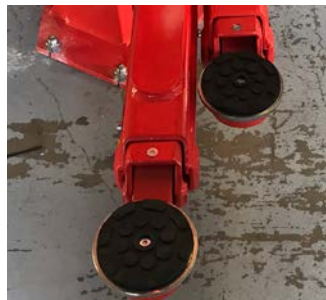

ADJUSTABLE PAD



**DUAL HEIGHT AND WIDTH
SETTING OPTION**

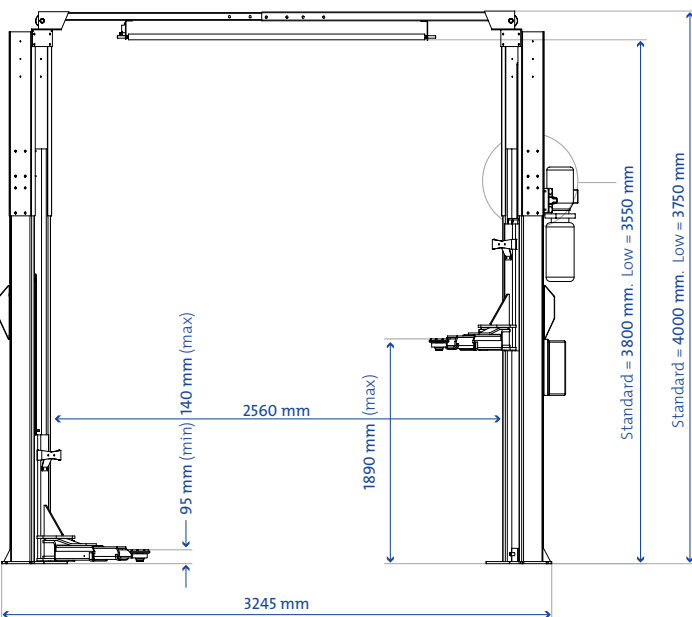

**LOW ARM CONSTRUCTION
– 95 mm**



**100MM PAD EXTENSION
SET INCLUDED**



**EASY OPERATION.
AUTOMATIC LOCK RELEASE**



**PATENTED AND RIGID
COLUMN PROFILE**

Specifications/Images subject to change without prior notice. To validate warranty, proof of a valid maintenance contract will be required. Images and Illustrations are indicative and may be modified without notice

**Lifting
the Level**

For more information, please
contact MOLNAR or your
local MOLNAR Representative

☎ 1300 MOLNAR (1300 665 627)
☎ 08 8234 3611 📠 08 8234 4322
✉ sales@molnarhoists.com.au

www.molnarhoists.com.au

🌐 📘 MolnarAustralia

SM245

Universal Electro-Hydraulic Two Post Vehicle Hoist – 4.5 Tonne Capacity



MOLNAR

PART OF THE STENHØJ GROUP

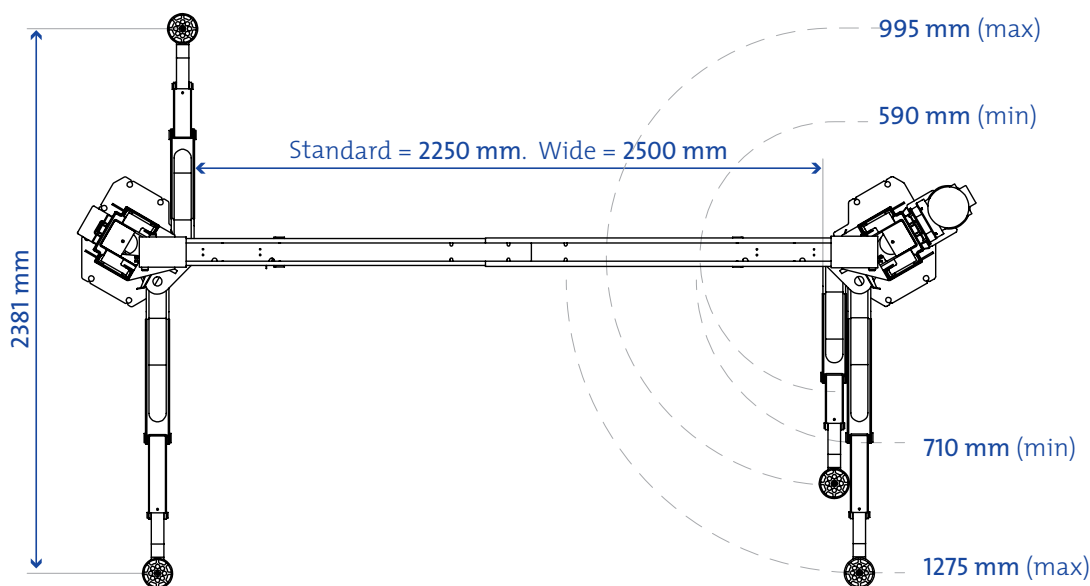
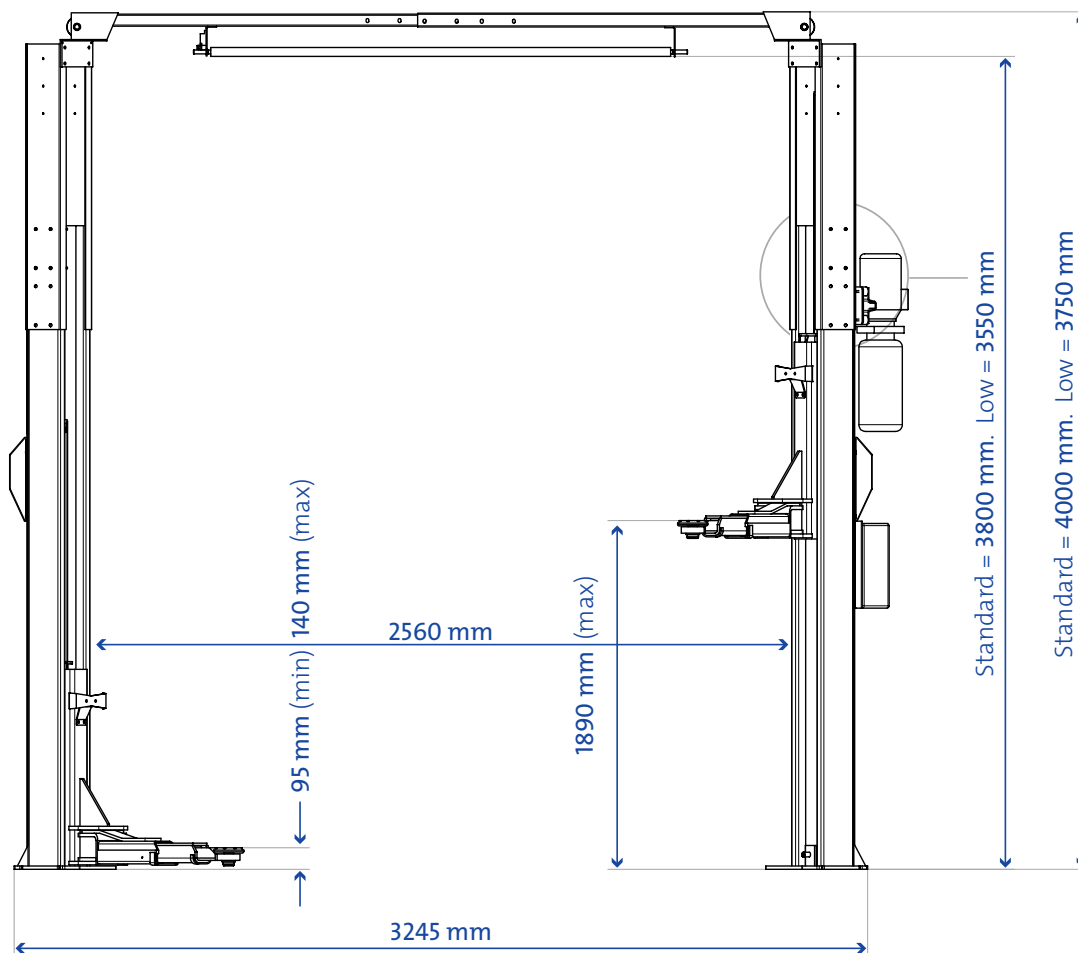

Illustrations are indicative and may be modified without notice

*Lifting
the Level*

For more information, please contact MOLNAR or your local MOLNAR Representative

www.molnarhoists.com.au

☎ 1300 MOLNAR (1300 665 627)
☎ 08 8234 3611 📠 08 8234 4322
✉ sales@molnarhoists.com.au

🌐 www.molnarhoists.com.au MolnarAustralia