

Installation instructions for 715309 Max deviation Wheel free
BRADBURY WHEEL-FREE H4441 / H4443 / H4541 / H4543

1. Install the S23 switch between the two cross-beams on the front right wheel-free cross beam.

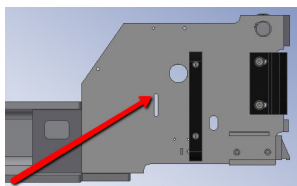

Use the existing machined slot to install a screw (253595) washer (214771) and nut (240306) in the left switch hole.

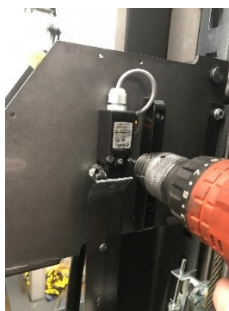

2. Drill a 4,2 mm hole in the bottom right S23 switch hole and make a M5 thread. Install a screw (253595) in the new thread.

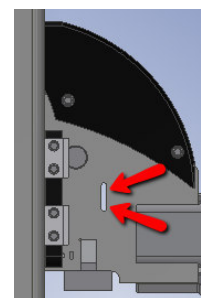

3. Use the existing machined slot outside on the main cross beams front right side: Install the max deviation bracket (609366) with bracket (474627) and two screw (254646).
4. Install the S23 switch wire to the control according the electrical diagram on next page.
5. On the control covers backside. Remove the bottom red wire from the push DOWN-button and install this cable in the cable connector.
 On the short red wire between park- and push DOWN-button remove the wire connected to the push DOWN-

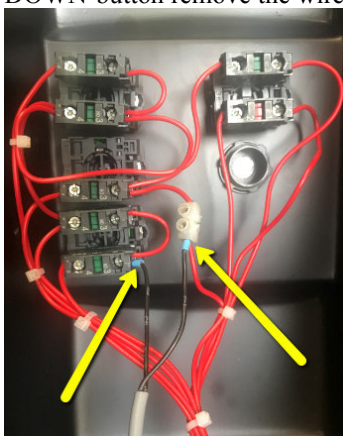

button and connect it to the cable connector:

The two yellow arrows indicate the S23 switch-cables. One S23 cable are connected to the cable connector and the other S23 cable to the push DOWN-button.

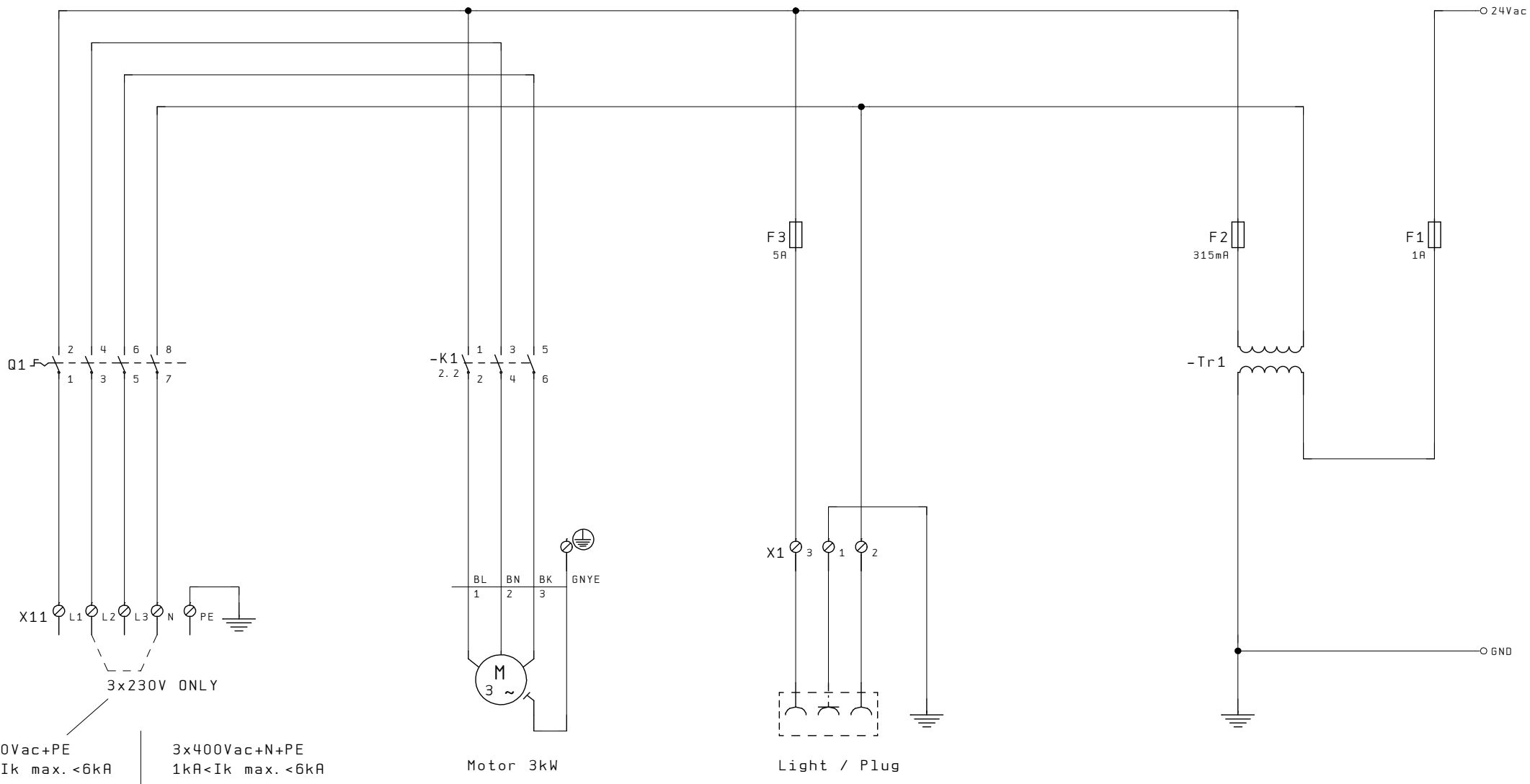

REV.	5
Project date	14. Mar. 2007
Printed	09. Sep. 2019

Nøgleskema - H4	
Schematic nr. T50529	Page 1
	of 4

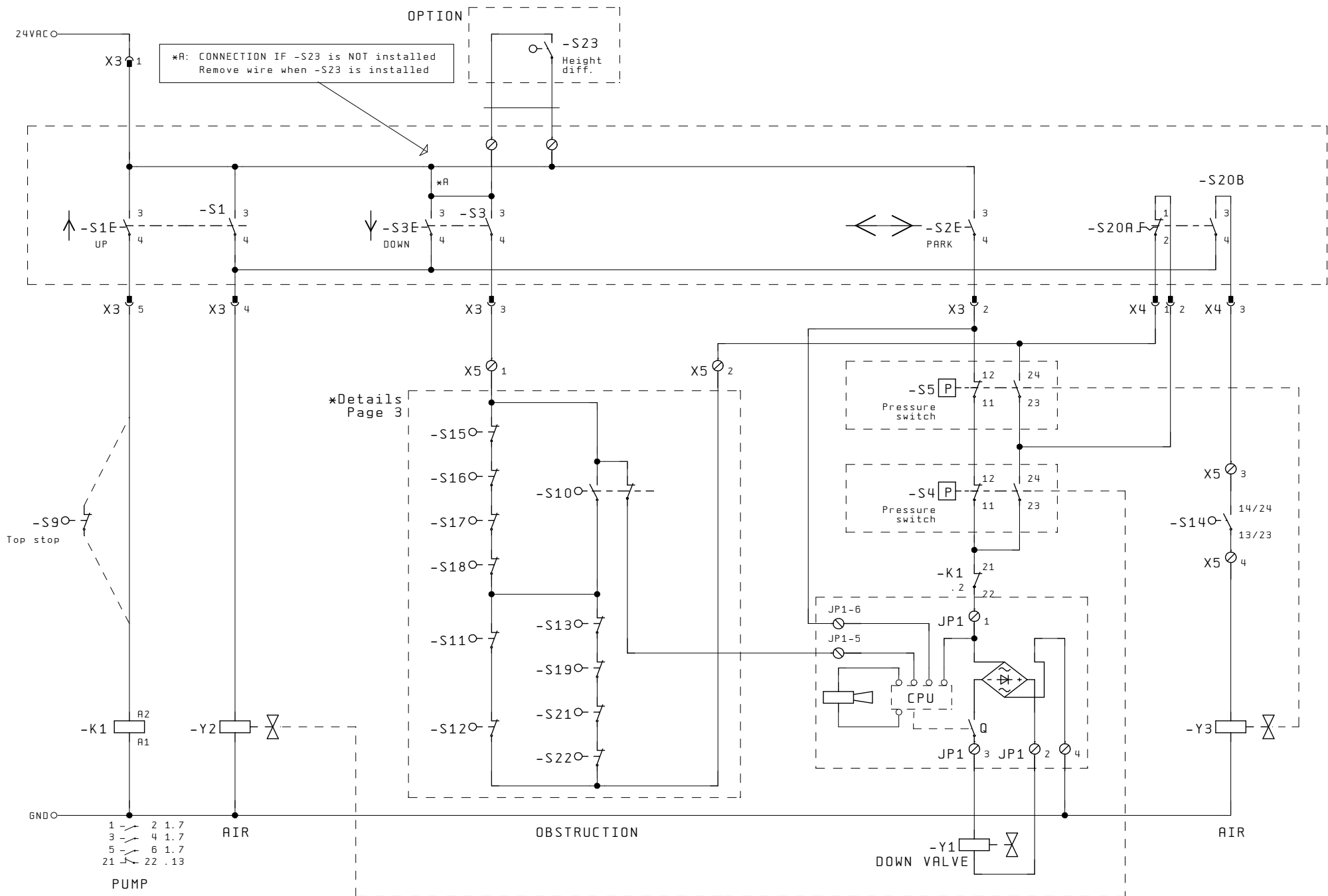

REV.	5
Project date	14. Mar. 2007
Printed	09. Sep. 2019

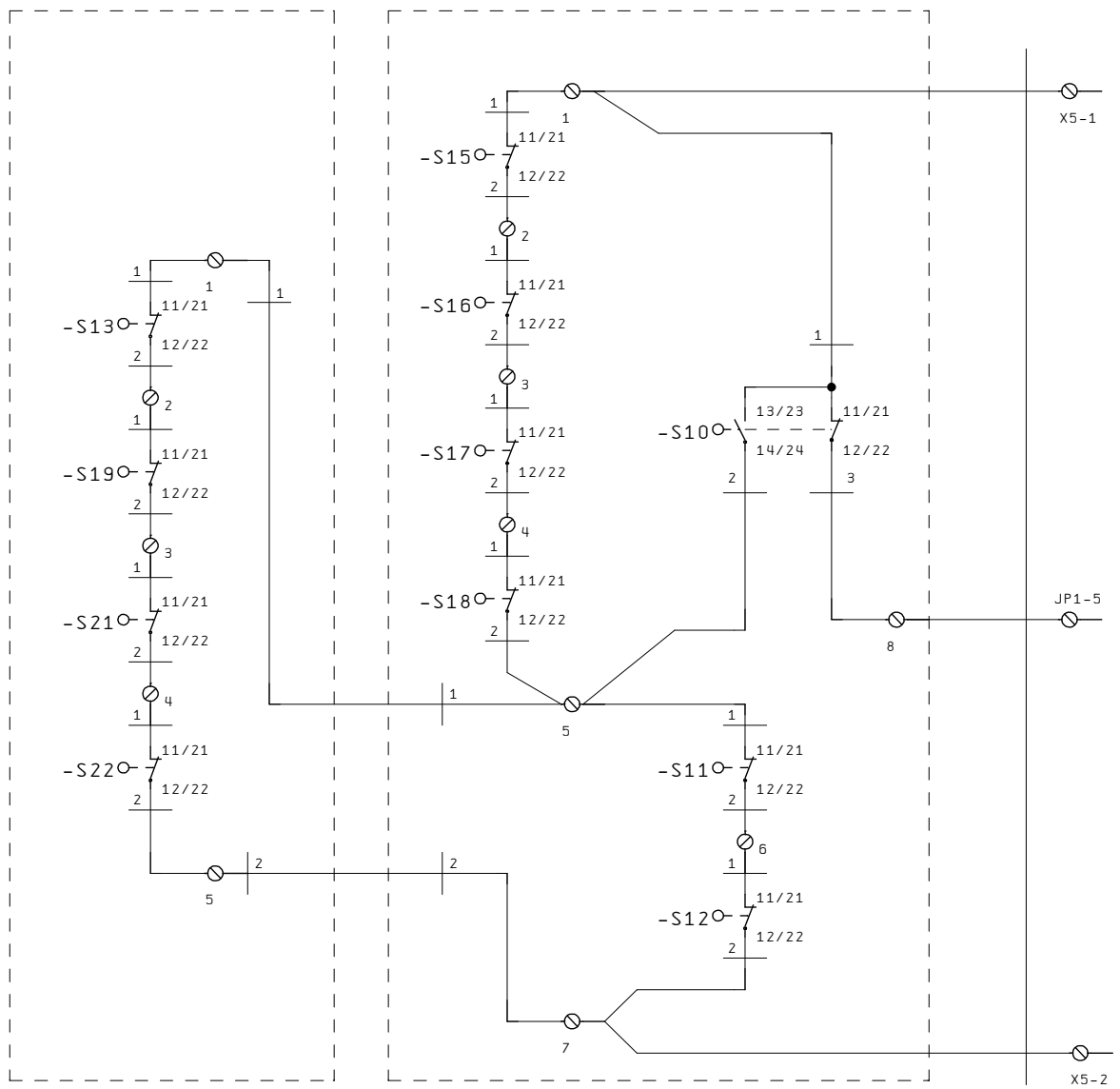

OBSTRUCTION

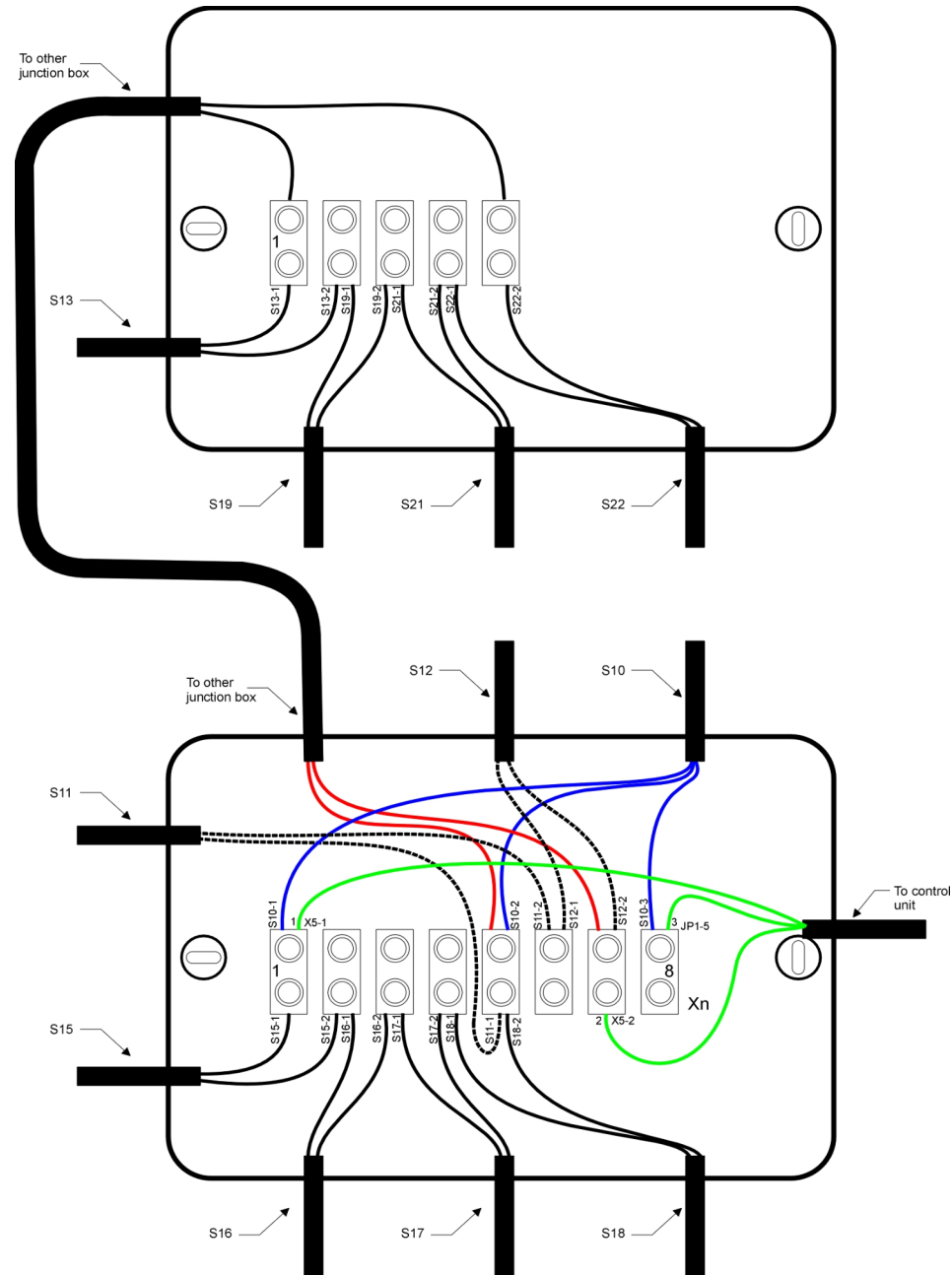

Limit switches:

- S10: Limit switch for jumping the obstruction system on main lift, when lift is in bottom position.
- S11: Limit switch for obstruction system for wheel free device - rear
- S12: Limit switch for obstruction system for wheel free device - front
- S13: Safety switch for ratchet when parking front right wheel-free cross beam.
- S14: Limit switch for jumping S20 (in order to avoid that ratchets on safety ratchets are pulled, when wheel free device is parked).
"Normally open" contacts has to be used in this switch.
- S15: Limit switch for obstruction system on main lift
- S16: Limit switch for obstruction system on main lift
- S17: Limit switch for obstruction system on main lift
- S18: Limit switch for obstruction system on main lift
- S19: Safety switch for ratchet when parking front left wheel-free cross beam.
- S20: Rotary switch for control of the Y3 valve
- S21: Safety switch for ratchet when parking rear right wheel-free cross beam.
- S22: Safety switch for ratchet when parking rear left wheel-free cross beam.
- S23: Limit switch for Max height difference between wheel-free and platform.